

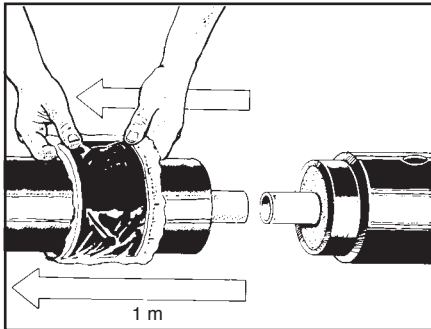

Material and equipment

- Appropriate size TPSM-PE sleeve
- Propane gas tank, regulator and gauge
- Thermo-indicator
- Hose and torch
- Safety equipment as prescribed by local regulations



Preparation

Before welding the service pipe, slide one sleeve over each pipe end and position about one meter away from the cutback area.

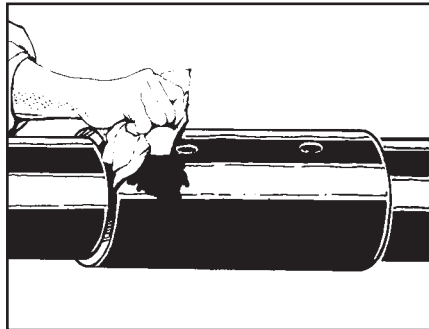

After the joint is foamed, jacket and casing areas should be dry and free of foreign materials such as oils, greases, dirt and excess polyurethane foam. To remove grease, use a cloth soaked with degreasing solvent. Follow the handling instructions given by the solvent supplier.

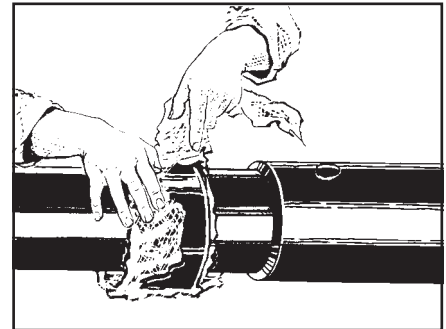

Remove the plastic bag from the sleeve. Do not remove the inside release liner yet.

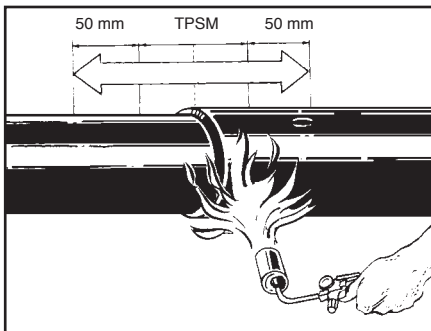

Preheating

Preheat oversized casing and jacket areas evenly to approximately 60°C using a soft flame. Let the heat penetrate well.

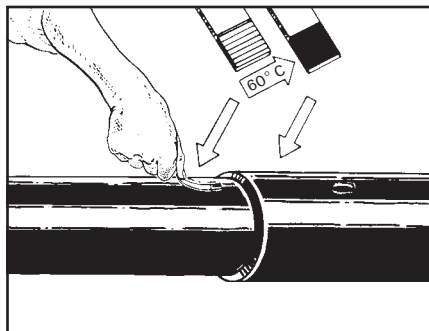

Check temperature with the thermo-indicator. An immediate color change indicates enough heat has been applied.

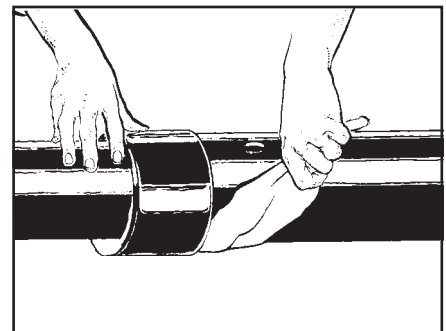

Sleeve installation

Center the sleeve over the casing end and remove the inner release liner.

TPSM-PE

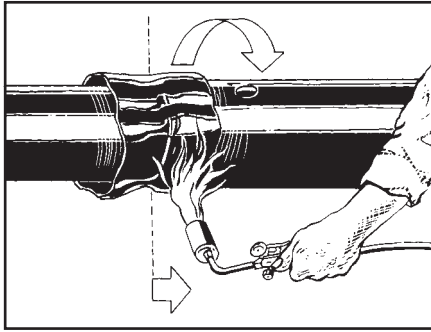

Using a steady yellow flame, shrink the sleeve in the center, starting at the top and gradually working downwards in a paintbrush motion. While heating, the embossed or dimpled pattern on the sheet surface should change to a smooth surface. Work toward one end until the material has fully recovered and adhesive exudes from the sleeve end.

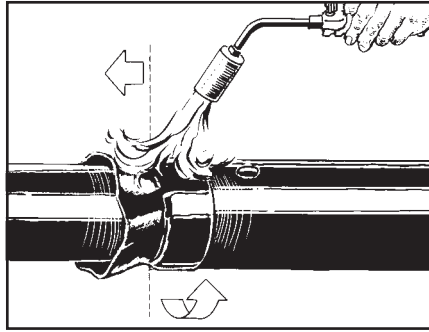

Repeat the process working toward the opposite end. Apply heat evenly around the sleeve, moving the flame constantly. Repeat the sequence for the other sleeve. Installation is finished when the sleeve is completely smooth and adhesive exudes at sleeve edges.

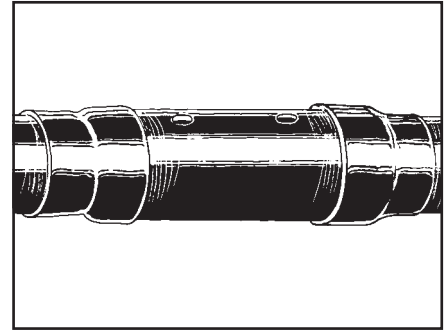

Visual inspection

Sleeves will be smooth without upstanding edges, dimples or cold spots. The pattern of the dimpled or embossed backing should be completely disappeared. Adhesive exudation will be evident along total circumference of the sleeves.

Berry Plastics warrants that the product conforms to its chemical and physical description and is appropriate for the use stated on the technical data sheet when used in compliance with Berry Plastics written instructions. Since many installation factors are beyond the control of Berry Plastics, the user shall determine the suitability of the products for the intended use and assume all risks and liabilities in connection herewith. Berry Plastics liability is stated in the standard terms and conditions of sale. Berry Plastics makes no other warranty either expressed or implied. All information contained in this technical data sheet is to be used as a guide and is subject to change without notice. This technical data sheet supersedes all previous data sheets on this product.

BERRY
PLASTICS
CORPORATION
AND SUBSIDIARIES

CORROSION PROTECTION GROUP
www.berrycpg.com

Local Distributor / Representative:

For contact details of local Distributors / Representatives
Please visit www.berrycpg.com.

Headquarters : Berry Plastics Tapes & Coatings Division, Franklin MA, USA

Franklin, MA, USA

Tel: +1 508 918 1714
US Toll Free: +1 800 248 0149
Fax: +1 508 918 1910
CPG@berrypastics.com

Houston, TX, USA

Tel: +1 713 676 0085
US Toll Free: 01 888 676 7202
Fax: +1 713 676 0086
CPGH@berrypastics.com

Tijuana, Mexico

Tel USA +1 858 633 9797
Fax US: +1 858 633 9740
Tel Mexico: +52 664 647 4397
Fax Mexico: +52 664 647 4370
CPGTJ@berrypastics.com

Westerlo, Belgium

Tel. +32 14 722500
Fax +32 14 722570
CPGE@berrypastics.com

Baroda, India

Tel: +91 2667 264721
Fax: +91 2667 264724
CPGIN@berrypastics.com